



Ural (Урал) - Dnepr (Днепр)
Russian Motorcycle
Drum Brakes
Part I: Introduction
(Front, Rear and Sidecar; Prior to 2014)

Ernie Franke
eafranke@tampabay.rr.com
July 2014

Russian (Ural and Dnepr) Motorcycle Brake History

- **Urals thru 2002 and All Dneprs: Manual Drum (Shoe-Type) Brakes in Front, Rear & Sidecar**
 - **All Three Wheels Interchangeable**
- **Urals 2003 thru 2013: Hydraulic Disc in Front (See Part I: Brembo Disc Brakes) and Manual Drum Brakes in Rear and Sidecar**
 - **Front Hydraulic Disc Brake Consists of Caliper, Brake Pads and Wheel Disc**
 - **Rear and Sidecar Manual Drum Brake Consist of Drum, Drum Cover, Shoes and Lever-Activated Cams**
 - **Rear Brakes**
 - **Rear Wheel Brake Mounted in Final Drive Case**
 - **Actuated via Mechanical Linkage to Brake Pedal**
 - **Sidecar Brakes**
 - **Sidecar Wheel Brake Mechanically Linked to Rear Brake Pedal**
 - **Sidecar Brake Drum Cover Secured on Sidecar Wheel Axle and Held from Rotation by a Torque Stop**
 - **Sidecar Brake Shoes Interchangeable with Rear Brake Shoes**
 - **Brake Shoes**
 - **Brake Shoes Provided with Adjusting Bolts to Compensate for Wear of Shoe Linings**
 - **Brake Shoe Adjusting Bolts Used for Setting the Gap between Brake Shoes and Brake Drum**
 - **For Optimal Performance of Drum Brakes**
 - **Tighten Brake Cable Adjuster Until Slightest Drag on the Wheel, Then Back-Off 1 or 2 Turns**
 - **For Checking the Gap**
 - **Cover of Brake Drum and Final Drive Crankcase Have Inspection Holes, Sealed with Rubber Plug**
- **All Urals 2014+**
 - **All Three Brakes Hydraulic Disc Brakes (See Part III: Brembo Disc Brakes)**

Brembo Brakes are found on modern Urals (2003+), but not on Dneprs.

Motorcycle Brake History

- **Drum Brakes Used on Rear and Sidecar Wheel Today (pre-2014)**
 - **Brakes of All Wheels Linked Mechanically**
 - **Front Wheel Brake Linked by Separate Cable from Handlebar Lever**
 - **Rear Wheel and Sidecar Brakes Provided by Common Control Linkage from Foot Brake Pedal**
 - **Sidecar Linkage to Rear Wheel brake**
 - **Originally by Cable**
 - **Later Urals Linked by Mechanical Slotted Lever**
- **Drum Brakes Come in Two General Types:**
 - **Single Leading Shoe and Twin (Dual) Leading Shoe**
- **Parking Brake**
 - **Addition of Parking Brake to Rear Parking Break Linkage**
 - **Appeared on Dnepr MT-10.36 then MT-11, MT-16**
- **Ural's Retro Utilized Front Hydraulic Drum Brake**
 - **Allowed Retention of Three-Wheel Interchangeability**
 - **Unfortunately, U.S. and European Requirements Do Not Allow Installation of Drum Brake on Front Wheel of a Motorcycle**
 - **Modern Export Models Have the Brembo Disc**

Starting in 2014, Ural returned to three-wheel interchangeability.

M-66 (Ural-3)

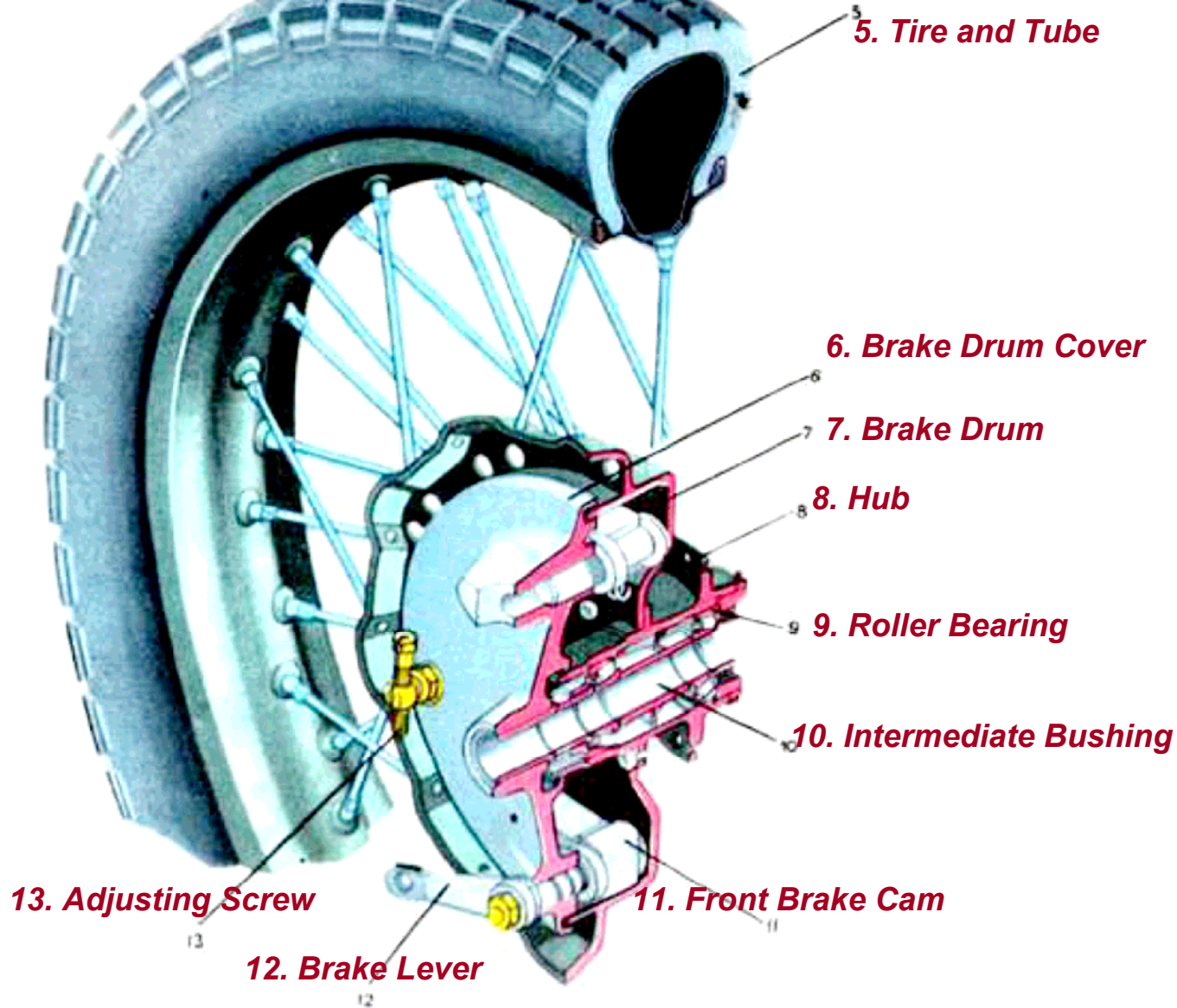

**Drum brakes are activated by a lever which turns a cam.
Distance between the shoe and the drum is set by an adjusting screw.**

M-66 (Ural-3)

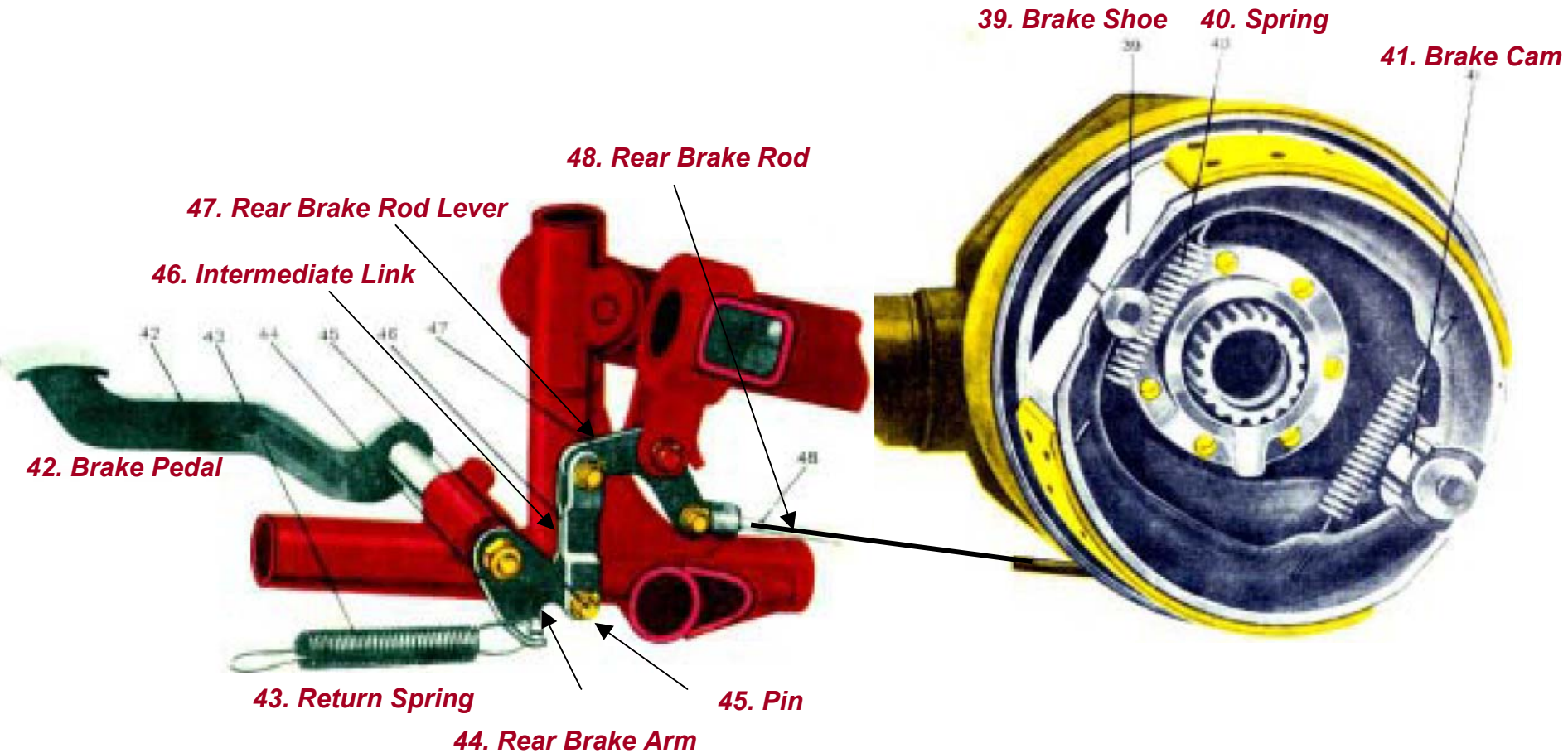

The rear brake is energized by the foot pedal and mechanically connected to the drum brake by a tie rod.

Main Gear, Drive Shaft

ii

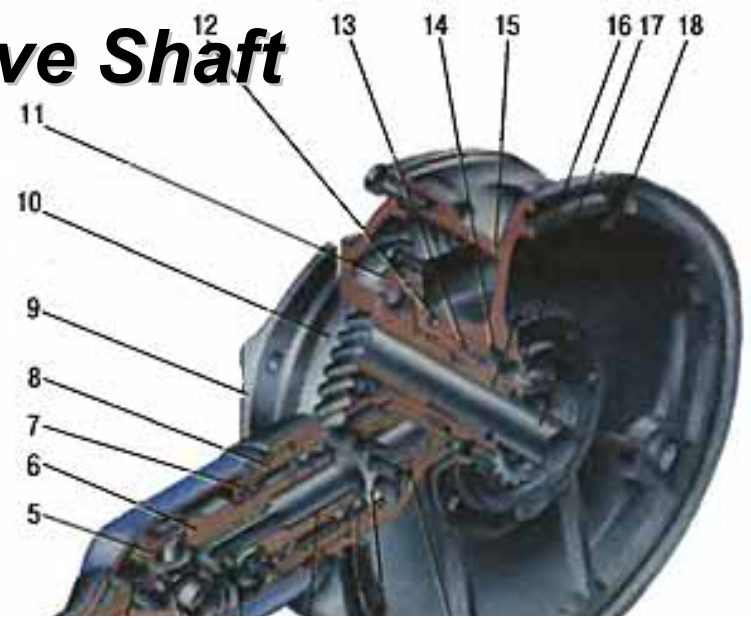

28 - Brake Pad, 29 - Driven Gear Hub, 30 - Brake Shoes, 31 - Return Spring, 32 - Adjusting Focus, 33 - Brake Rod

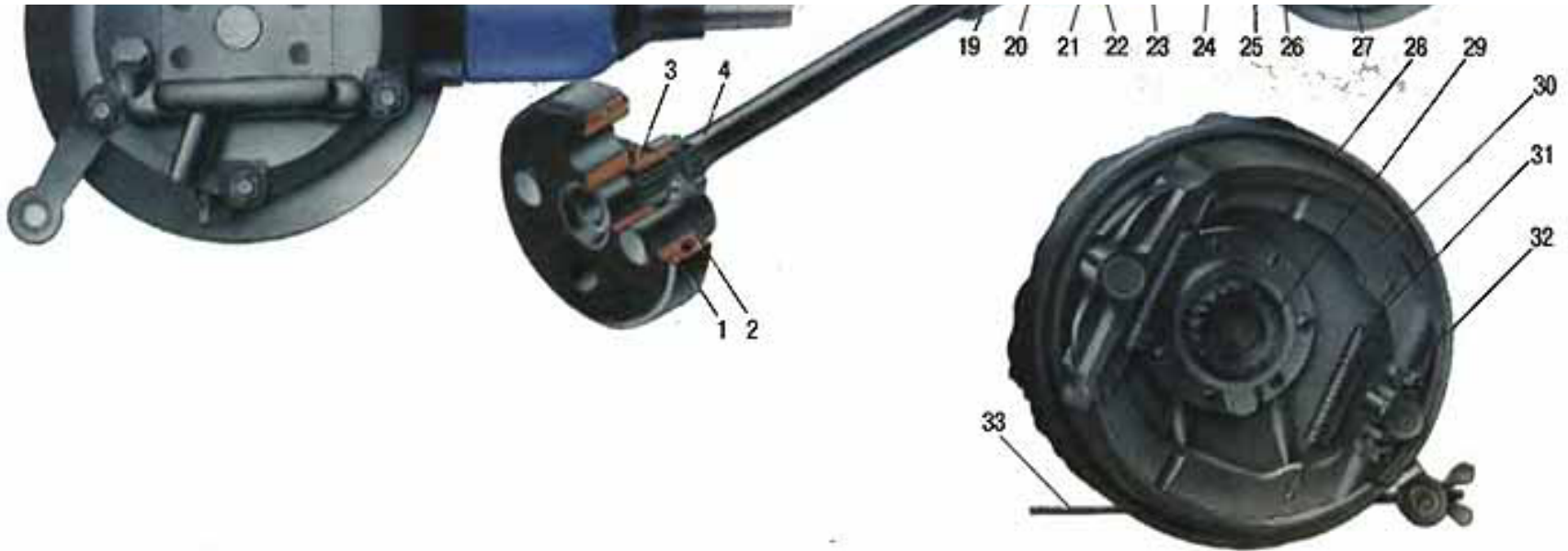

The rear brake is attached to the drive shaft case.

Rear Brake Pedal (2009 Ural T)



Rear and Sidecar Brake Pedal

Mechanical Link to Sidecar Brake

On modern Urals, the rear wheel brake is activated by pedal, which is also mechanically linked to the sidecar brake.

One-Cam versus Two-Cam Drum Brakes

- **Drum Brakes Come in Two General Types**
 - **Single Leading Shoe and Twin (Dual) Leading Shoe**
 - **Single-Cam Leading Shoe Has Cam Which Pushes One Side of Each Brake Shoe**
 - **Twin-Cam Leading Shoe Has Two Cams on Each End of Brake Shoe**
 - **Twin-Cam Gives Better Shoe-to-Drum Contact, Increasing Braking Power**
 - **More difficult to adjust**
 - **If Not Adjusted Properly, Gives Less Braking Power than Single-Cam Shoe Type**
- **Brake Drum Formed Integrally with Wheel Hub**
- **Inside Drum Is Two Semicircular Brake Shoes (4)**
 - **Outer Surface Lined with Friction Material Conforming to Shape of Inner Surface of Drum**
- **Drum Brake Consists of:**
 - **1. Brake Drum; 2. Rotary Cam; 3. Spring; 4. Shoe; 5. Bearing (Pivot Point)**
- **Like Unclasping Fists, Shoes Rub Against Brake Drum**
- **Cam Activated by Lever**
 - **Front Brake Activated by Cable Connected to Brake Lever on Handlebars**
 - **Rear Brake Activated by Tie Rod Connected to Foot Pedal**

- 1. Brake Drum
- 2. Rotary Cam
- 3. Spring
- 4. Shoe

- 3. Spring
- 5. Bearing (Pivot)

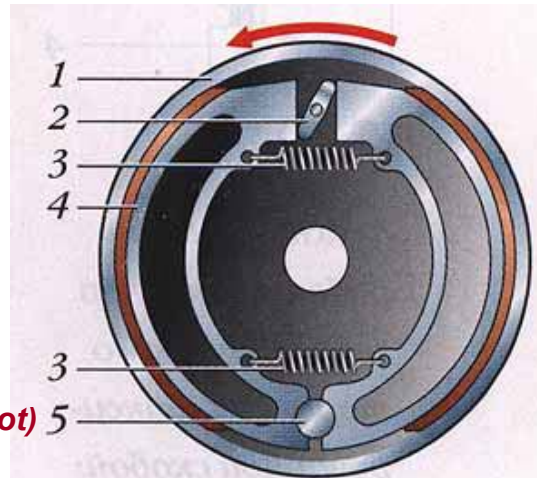

The cam rotates to expand both brake shoes, pivoting about a single point. The position of the pivot sets the distance between the shoe and the drum.

M-72 Drum Brakes

1	Brake Drum
2	Brake Drum Cover
3	Brake Pads
4	Oil Trap
5	Friction Lining
6	Axis Pad
7	Brake Fist
8	Springs
9	Brake Lever
10	To Brake cable
11	Front Brake Lever
12	Brake Traction
13	Brake Pedal
14	Adjusting Screw
15	Bell Crank

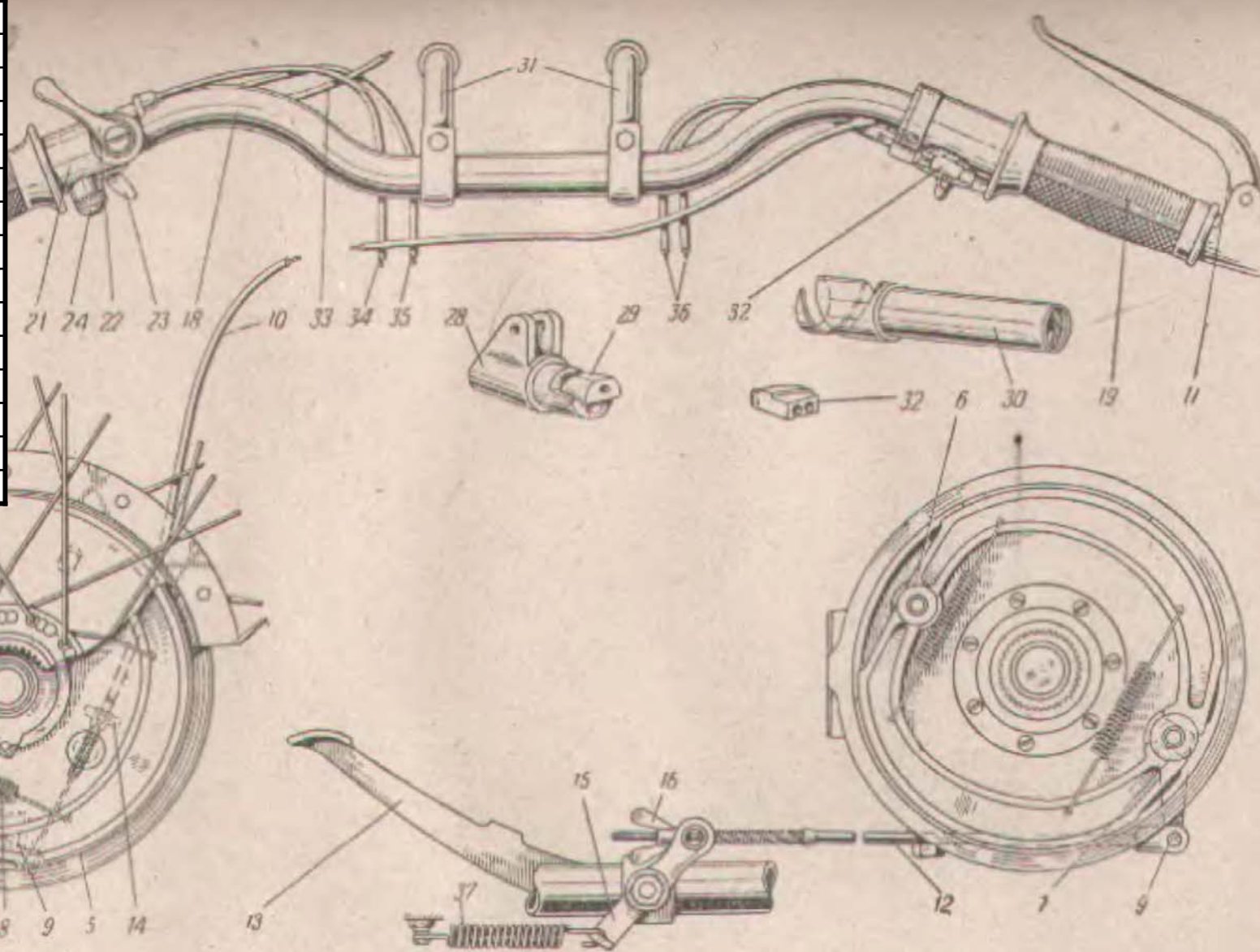

The M-72, father of heavy Russian motorcycles, uses single-cam drum brakes in the front and rear.

M-72 Single-Cam Drum Brakes

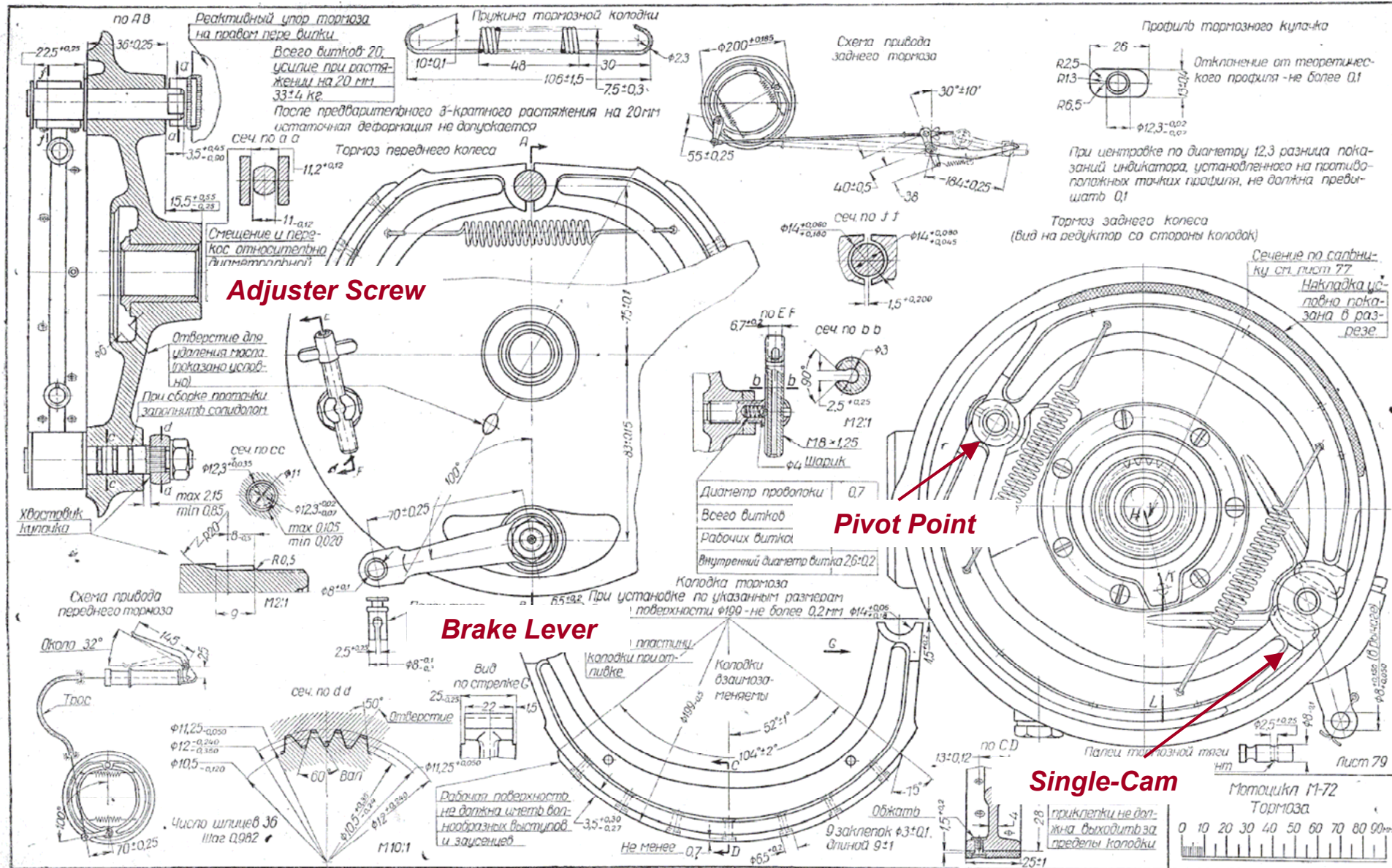

Starting with the M-72, the brakes had single cams.

M-61 Single-Cam Front Brake

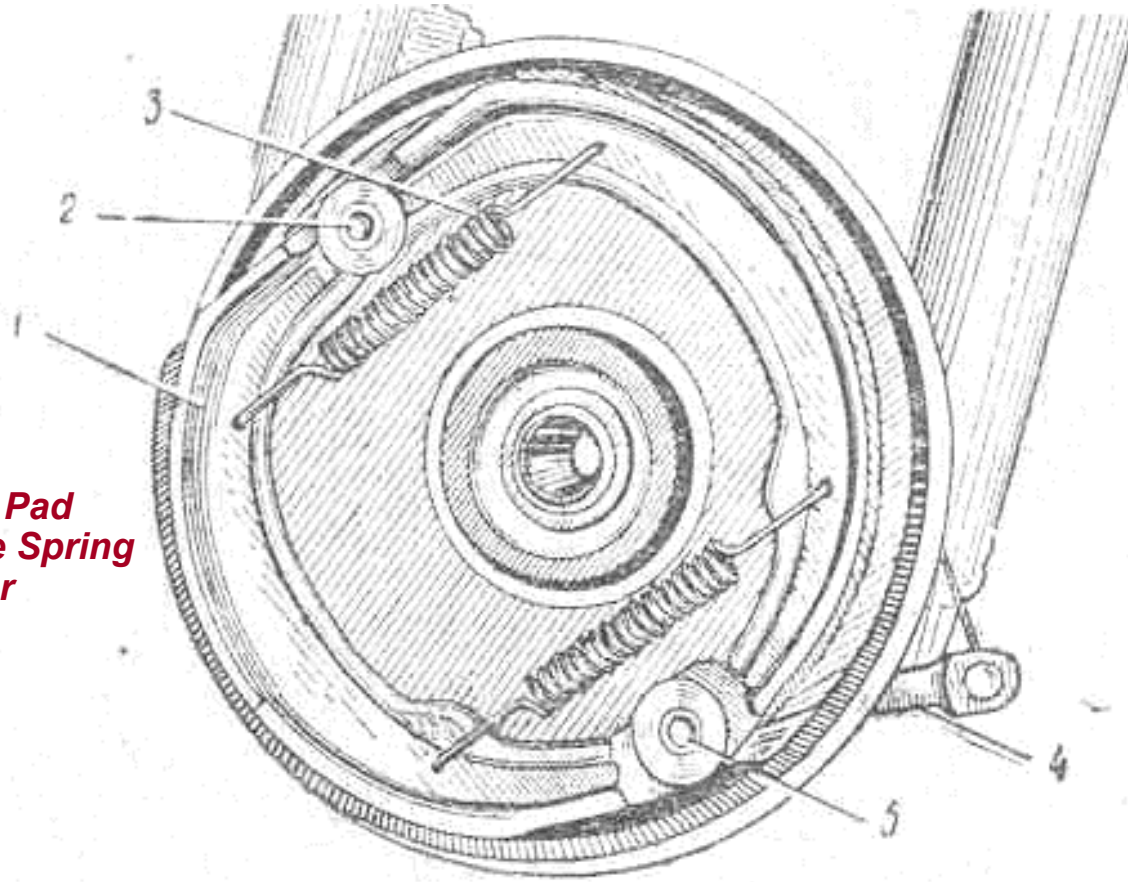

- 1. Brake Pad**
- 2. Axle Brake Pad**
- 3. Brake Shoe Spring**
- 4. Brake Lever**
- 5. Brake Cam**

K-750 Single-Cam Front Brake

Вид по А

1. Adjusting Cone
2. Tappet (Pusher)
3. Finger Lever
4. Lever
5. Fist Brakes
6. Rocker
7. Lever Screw
8. Brake Pads
9. Brake Shoe Spring

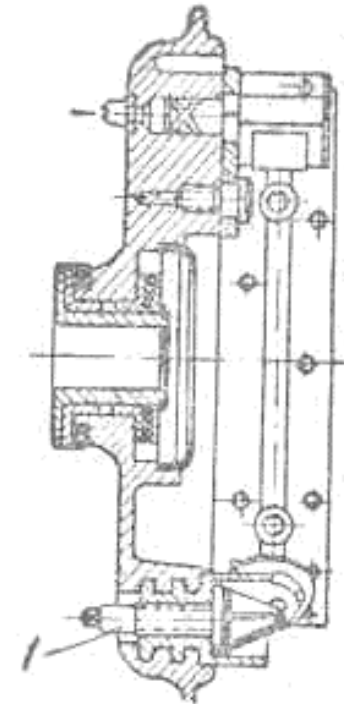
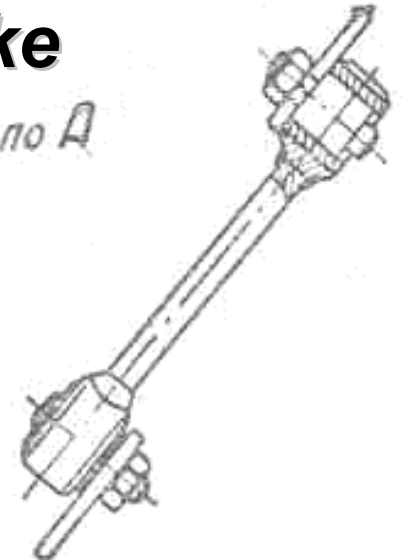
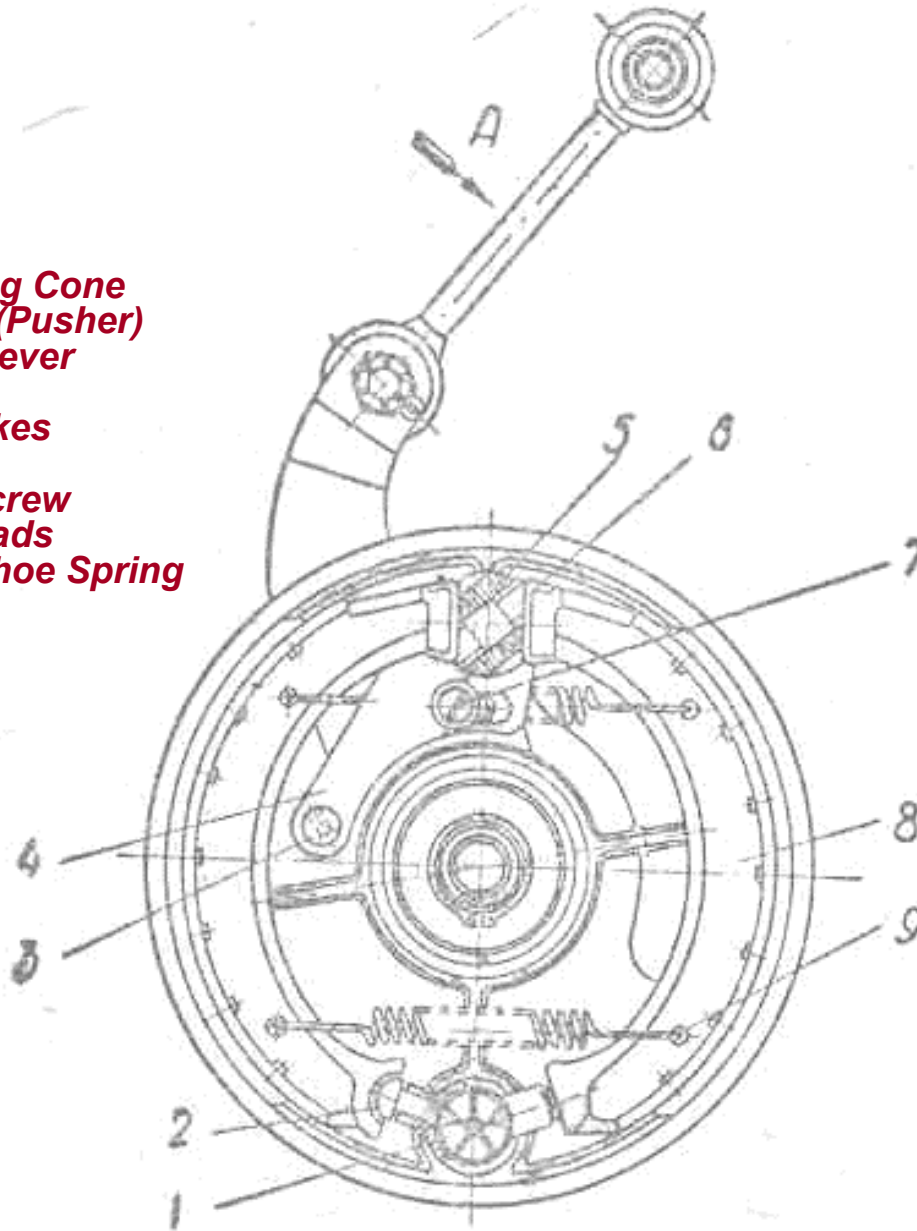

Front Wheel Dual-Cam Drum Brakes

- **Front Wheel Brake Is Double-Cam Type**
- **Tie Rod (11) of Upper and Lower Levers of Brake Factory-Adjusted to Length So Brake Cams Are Equalized**
- **To Return Levers to Initial Position, a Spring (9) Is Installed on Bottom Lever**
- **Brake Shoe Provided with Adjusting Bolts (5) to Compensate for Wear of Shoe Linings**
- **Adjusting Bolts Used to Set the Gap between Brake Shoes and Brake Drum**
- **Normal Operation Leaves a Gap between Shoes and the Drum**
 - **If No Gap: Brakes Will Overheat or Seize the Wheel**
 - **If Gap Is Too Large: Brake Cannot Be Fully Applied**
 - **Inspection Hole Provided in Cover of Brake Drum and Final drive Crankcase for Checking the Gap**

1. Upper Brake Lever

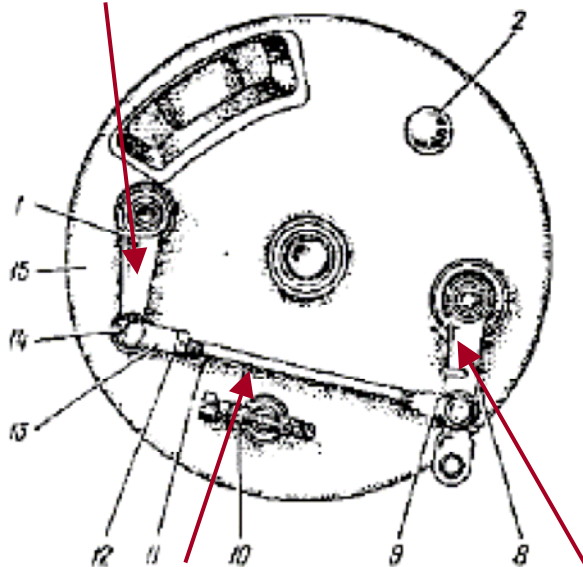

11. Tie Rod between Cams

Dual Cams

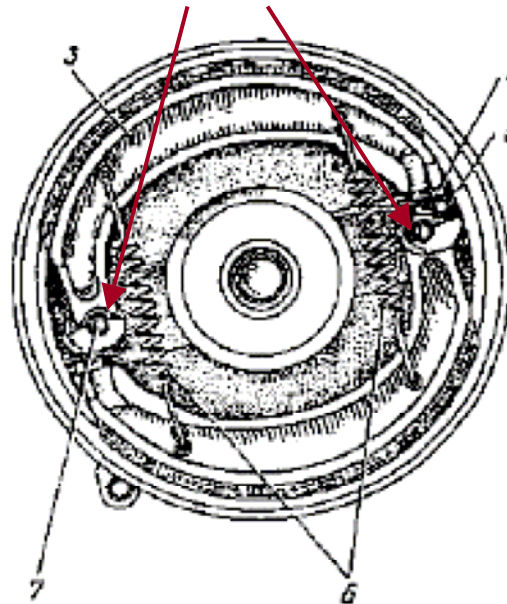

8. Lower Brake Lever

1	Upper Brake Lever
2	Inspection Hole Plug
3	Brake Shoe
4	Adjust Bolt Locknut
5	Adjusting Bolt
6	Brake Shoe Springs
7	Front Brake Cam
8	Lower Brake Lever
9	Brake Lever Spring
10	Adjusting Screw
11	Tie Rod
12	Locknut
13	Tie Rod Fork
14	Pin
15	Brake drum Cover

MB-650, MB-650M1, MT-12 Dual-Cam Front Wheel Brake

- Brake Shoes (1) Spherical Seats on Heads of Pusher (5)
- Pushers Rest on Cams (3) Installed in Disk (4)
- Driving (7) and Driven (8) Levers on Front Side of Brake Disk, Connected to Cam via Splines
- Levers Are Interconnected by Adjustable-Length Tie Rod (2)
- Driving Lever Connected by Cable to Control Lever on Handlebars
- Pressing on Lever, Cable Acts on Brake Driving Lever
- Both Levers Turn Cams Simultaneously to Spread Brake Shoe to Press Against Brake Drum
- Brake Shoes Returned to Original Position by Two Springs (6)

- 1. Brake Shoe
- 2. Tie Rod with Forks
- 3. Cam
- 4. Disk
- 5. Pusher
- 6. Spring
- 7. Driving lever
- 8. Driven Lever
- 9. Return Spring
- 10. Pin
- 11. Adjusting Union
- * Washer Not Shown

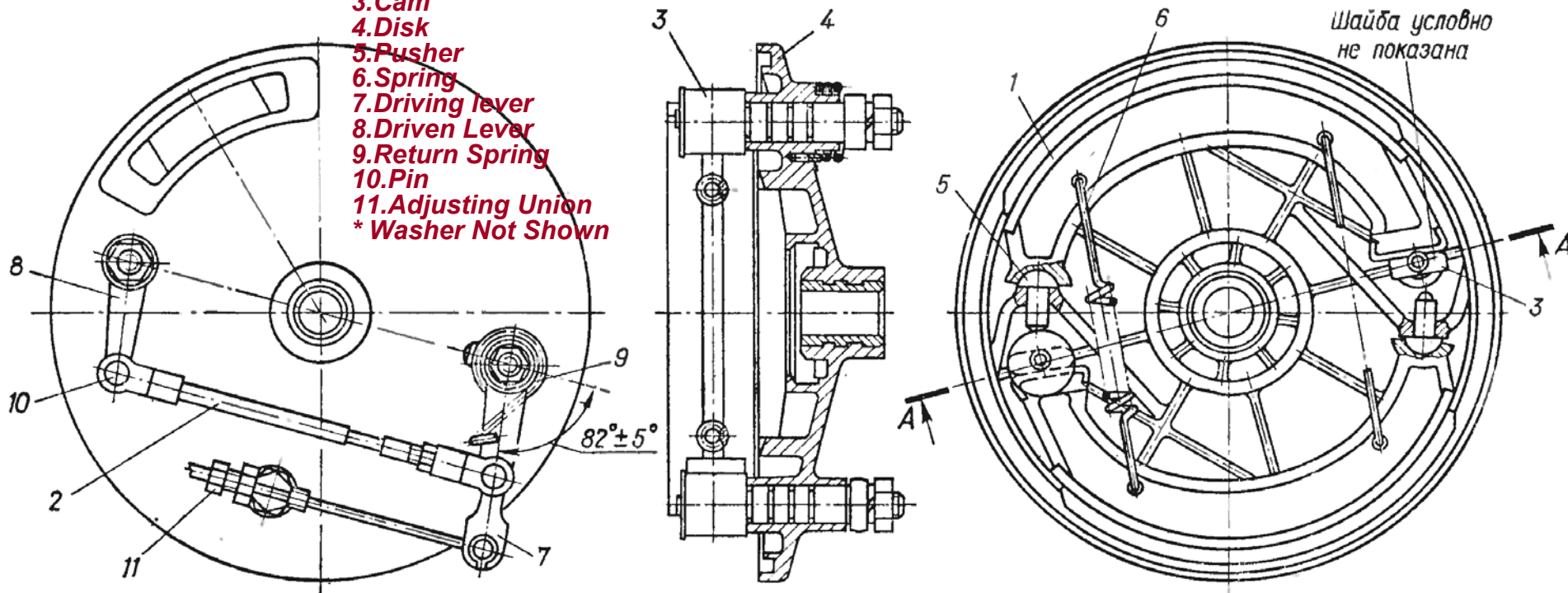

Double-Cam Brakes Ural IMZ-8.103 (750cc, 2000-2002)

1. Upper Link
2. Inspection Port
3. Brake Shoe
4. Against Adjusting Nut
5. Leveling Bolt
6. Spring Jaw
7. Front Brake Cam
8. Lower Link
9. Spring Rod
10. Leveling Screws
11. Tie Rod
12. Jam Nut
13. Rod Fork
14. Axis
15. Brake Flange

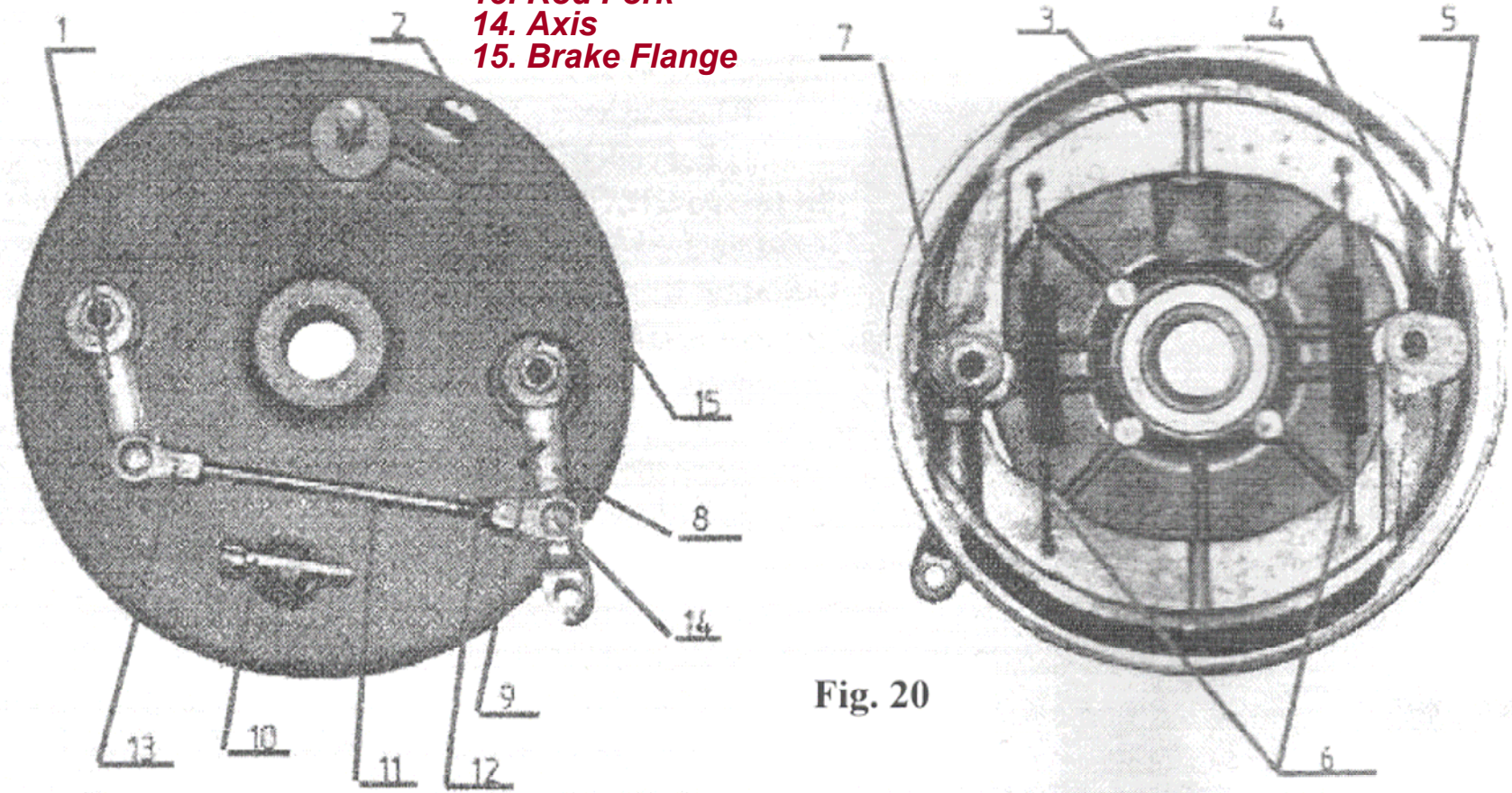
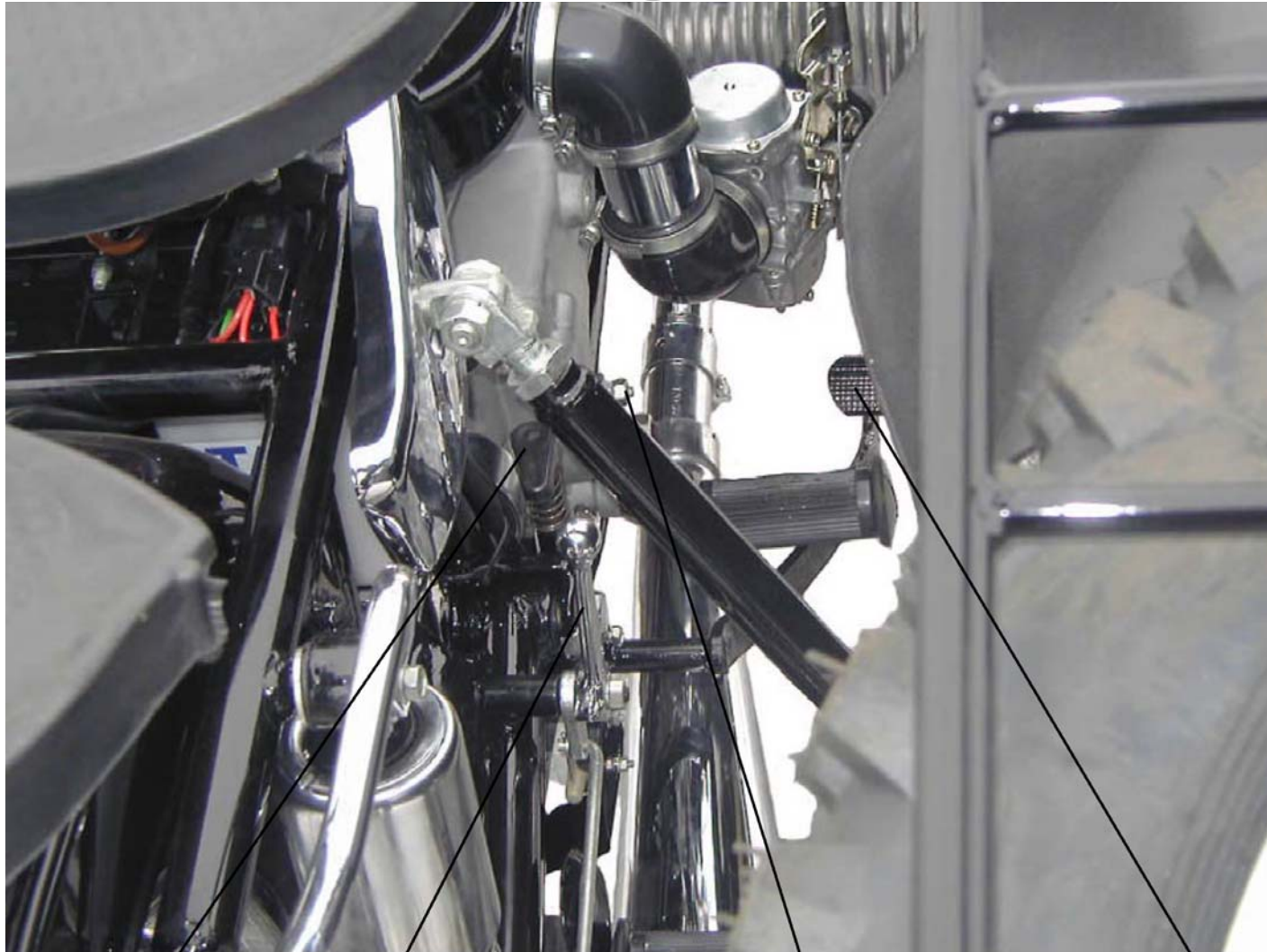

Fig. 20

Parking Brake



Parking Brake Sidecar Drive Lever Reverse Gear Lever Rear Brake Pedal

To engage the parking brake, depress the rear brake pedal and push down, then twist the parking brake lever counter-clockwise.

Front and Sidecar Wheel Brake Ural 8-103

- Sidecar Wheel Brake Connected to Rear Brake Pedal
- Sidecar Brake Drum Cover Secured on Sidecar Wheel Axle and Held from Rotation by a Torque Stop
- Sidecar Brake Shoes Are Interchangeable with Motorcycle Brake Shoes

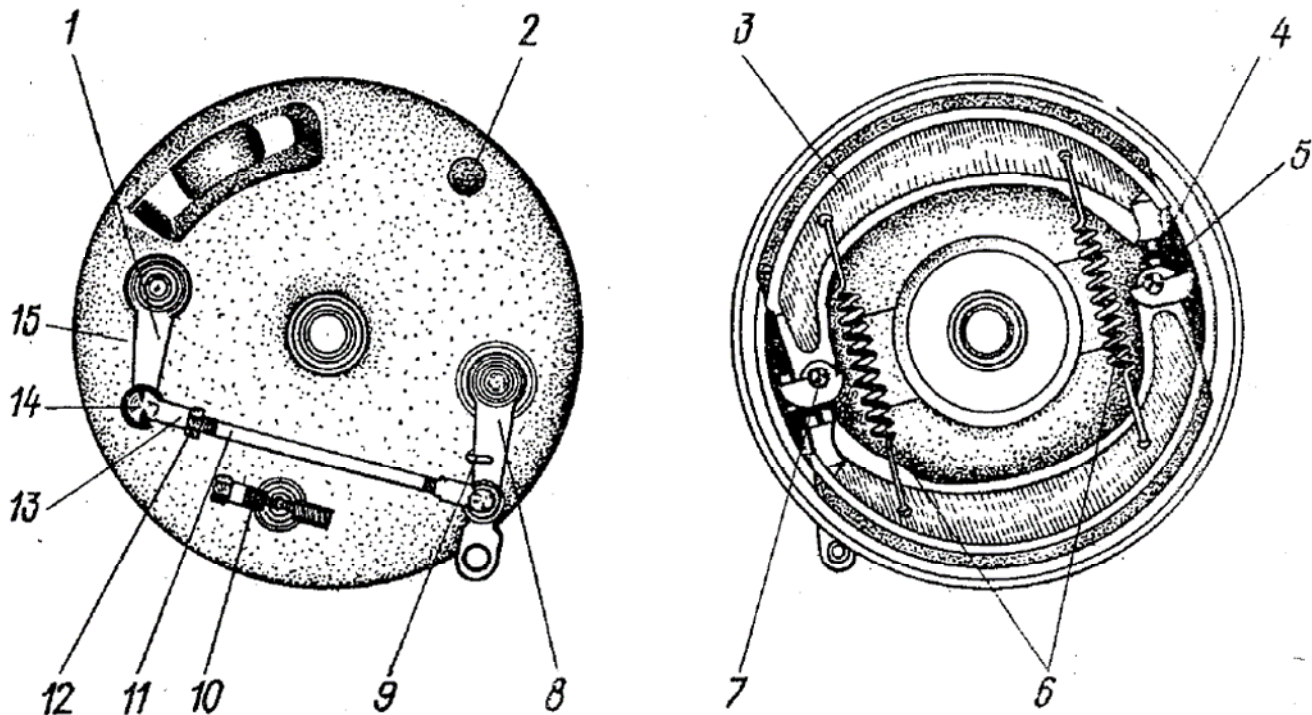

1. Upper Brake Lever
2. Sight Hole
3. Brake Shoe
4. Adjusting Bolt Lock-Nut
5. Thrust Bolt
6. Brake Shoe Spring
7. Front Brake Cam
8. Lower Brake Lever
9. Spring Brake Lever
10. Adjusting Screw
11. Intermediate Rod
12. Lock-Nut
13. Fork Rods
14. Leg
15. Brake Drum Cover

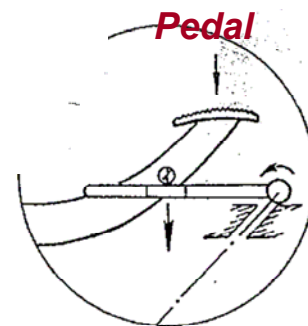

Ural 650 Drum Brake and Control Cable Adjustment

- **Need to Adjust Connector between the Two Brake Cam Levers (Arms)**
 - **Ensure Both Ends of Each Shoe Contacts Brake Drum at Same Time**
 - **Loosen Both the Cable Adjuster and the Rod Connecting the Two Brake Cam Levers**
 - **Tighten the Cable Adjuster (The One on the Brake Drum, Not the One on the Handlebar)**
 - **When Brake Starts to Drag, Keep Turning the Wheel and Get a Good "Feel" of How Much Drag There Is**
 - **Tighten Rod Going to Other Brake Cam Lever Until the Drag "Feels" About Twice as Much as Before**
 - **Tighten Locknut, Then Adjust Cable for at Least 1/8" of Play at the Handlebar Brake Lever**
 - **By Adjusting the Play You Can Make the Brake Lever Engage the Brake Wherever You Like**
 - **Like Closer to the Handlebar for Small Hands**
 - **Don't Be Afraid to Make the Lever Fit Your Hand**
 - **Just Make Sure There Is Enough Free Play in the Cable So the Brakes Don't Drag, and the Lever Does Not Touch the Handlebar When Full-On**
 - **How Do You Tell If They Are Dragging?**
 - **Feel the Drum after Riding Awhile**
 - **If It Is Really Hot and You Have Not Used the Brakes Much, They Are Dragging**
 - **If You're Sure the Brakes Are Not Dragging and the Drum Is Still Hot, Check Your Wheel Bearings**
- **Drum Brake Adjustment**
 - **Front Brake Lower Lever Set Distance of 85mm (3.3") from Vertical to Adjusting Screw Bracket center**
 - **Angle of Deviation of Rear Brake Lever Backward from vertical Axis of Final Drive Equal to $33 \pm 5^\circ$ Should Be Ensured After Disassembly Is Performed with Wheels Jacked Up**
 - **Proceed to Adjustment of Foot Brake, Starting from Rear Wheel**
 - **Slack Off the Nut on Tie Rod of Sidecar Wheel Brake**
 - **Adjust Sidecar Wheel Brake by Tightening Nut on Brake Tie Rod**
 - **After Foot Brake adjusted Properly, Back-Up the Nut on Tie Rod of Sidecar Wheel Brake by 2-3 Turns to Keep It from Pulling to Right When Applying the Brakes**
 - **Brakes Should Be Inspected for Wear Every 2,500 to 5,000 km**
 - **If Brake Shoe friction Material (Lining) Is 1/16" Thick or Less (thickness of a nickel), Shoes Must Be Replaced**
- **Brake Control Cable Adjustment**
 - **0.3 – 0.7 mm (0.012 – 0.028") Gap Between Brake Shoes and Brake Drum**
 - **5 – 8 mm (0.2 – 0.3") Play of Front Brake Control lever and Play of Rear Brake Pedal Equal about 25 – 30 mm (1 – 1.2) of Full Stroke of the Pedal Required**
- **Front Brake Performance Less than Impressive: Examine Gripping Using Chalk**
 - **Mark Brake Shoes with Chalk**
 - **Remove Brakes**
 - **Examine Where Chalk Has Rubbed**
 - **Adjusting the Shoes and Repeat the Process**
 - **<http://www.russianiron.com/forums>**

Rear Drum Brake (2010 Ural T)



**The rear wheel brake is housed in the rear final drive.
The rear wheel brake is activated by the foot pedal.**

Rear Drum Brake Adjustment

- Rear Brakes Are Shaft-Operated
- Need about 1/2" of Play
- Adjusted by Nut on Rear End of Tie Rod, Activated by Rear Brake Pedal
- Most Are of Single-Cam Leading Shoe Type
- Repair Just Like the Front Brakes.
- When Everything Is Back Together
 - Before Tightening the Axle, Spin the Wheel and Put on Brake Hard and Hold It
 - Still Holding the Brake On, Tighten the Axle
 - This Aligns the Brake Shoes and Drum, Making the Brake Work Better
 - Do This for Both Front and Back Drum Brakes, Single- or Twin-Cam Leading Shoe

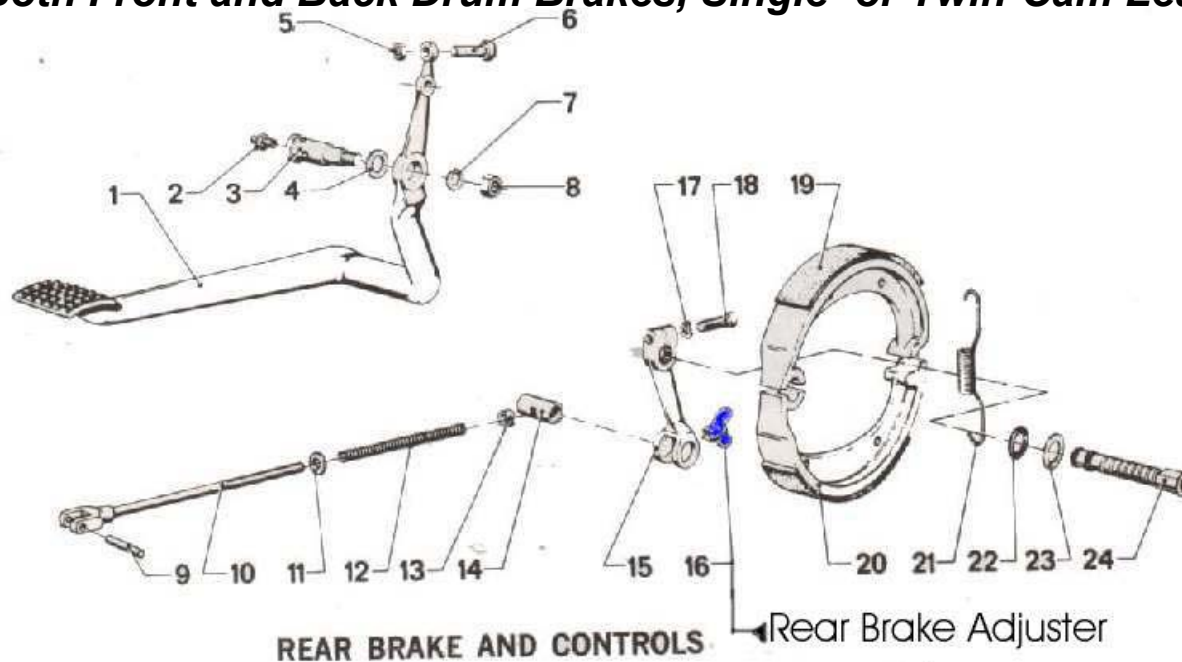

1. Foot brake lever
2. Grease fitting
3. Pin for foot brake lever
4. Shim
5. Hex nut
6. Hex head bolt
7. Spring washer
8. Hex nut

9. Brake rod pin
10. Brake rod
11. Circlip for brake rod
12. Spring
13. Spacer
14. Transverse pin
15. Brake lever
16. Wing nut

17. Spring washer
18. Alien head bolt
19. Upper rear brake shoe
20. Lower rear brake shoe
21. Return spring
22. Felt seal
23. Washer
24. Rear brake cam

MB-650 and MB-650M1 Front Wheel Brake

- **Compensation for Wear of Brake Linings**
 - **Initially Compensation Corrected by Tensioning of Cable Using Adjusting Union (11)**
 - **If Adjustment with Wear Using Union:**
 - **Fully Tighten Union**
 - **Remove Both (Driving and Driven) Levers from Cams**
 - **Install Levers to New position by Turning Counterclockwise Relative to Cams thru 10° (thru One Tooth)**
 - **Adjust Brake by Unscrewing the Union**
 - **If Length of Union Is Insufficient, disassemble Brake and Turn Cams Around Own Axle thru 180°**
 - **Owing to Asymmetry of Cam Relative to axis of Stem, Brake Shoe Is Set to Position in Which the Wear of Brake Linings Is Compensated on Diameter thru 3 mm**
 - **When Wear Is Less, Cam Turn Is Premature and Brake Shoes Will Not Fit in Brake Drum**
 - **Addition Compensation for Brake Lining Wear accomplished by Fitting Adjusting Shims of Similar Thickness between Pushers and Their Supports in Brake Disk**
- **Disassembly of Brake Straight Forward**
- **Assembly of Front Wheel Brake**
 - **Install Cams into disk Holes**
 - **Install Return Spring (9) by Direct Catch with Hole in Disk**
 - **Install Brake Shoes with Springs on Spherical Ends of Pushers and Bearing Surfaces of Cams**
 - **Install and Fix Driving and Driven Levers on Cam Splines Maintaining Angle of $82^{\circ} \pm 5^{\circ}$**
 - **Non-Parallelism of Levers Must Not Exceed 5°**
 - **Connect Tie Rod to Driving Lever After Installation of Brake on Motorcycle**
 - **Turn Each Lever Clockwise Until brake Shoes Pressed Against Wheel Brake Drum**
 - **Adjust Distance between Hole Centers in the Forks by Unscrewing or Screwing Tie Rod into Forks So Pin, Connecting Fork to Driven Lever, Would freely Enter the Holes in Lever and Fork**
 - **Tie Rod Must Be Screwed into Fork thru Length at Least 5 mm**
 - **Lock Tie Rod on the Fork, Connect Tie Rod to Driven Lever and Lock with Cotter pin**
 - **Insert Return Spring**

K-650, MB-650, MB-650, MB-650M1 and MT12 Rear Wheel Brake

- Brake Shoes (8) Rest by Seats on Heads of Pusher (2), Pressed Against a Cam (5)
- Cam Has a Slot in Which Equalizer (6) Is Installed
- When Cam with Equalizer Is Turned, Brake Shoes are Pressed to Brake Drum
- As Brake Linings Wear Out, Clearance between Brake Shoes and Brake Drums of the Wheel Increases
- To Maintain Proper Clearance, Wear Compensator Adjusting Taper (1) Is Used
- When Necessary, Taper Is Screwed In (from the Outer side of the Brake) and Spreads Pusher (2), Which Bring the Brake Nearer to the Drum and Cam
- To Fix the Position of the Taper, Longitudinal Grooves Are Envisaged On Its Surface, into Which the Pushers Enter Under Action of Springs (9), Which Draw Brake Shoes Together
- Necessity of Brake Adjustment Determined by Amount of Free travel of Outer Hinge (12)
 - Free travel Considered to Be normal When It Does Not Exceed 5 mm
 - When Greater than 5 mm, Lift Rear Wheel and Using Open-End 8mm Wrench Turn Protruding Square of Adjusting Taper Clockwise Until Brake Shoe Begins to Touch Brake Drum During Rotation of the Wheel
 - After This, Turn Adjusting Taper Backward thru One Fixed Interval, so That Wheel Can Rotate Without Touching Brake Shoe

1. Adjusting Taper
2. Pusher
3. Lever Axle
4. Lever
5. Cam
6. Equalizer
7. Lever Screw
8. Brake Shoe
9. Brake Shoe Spring

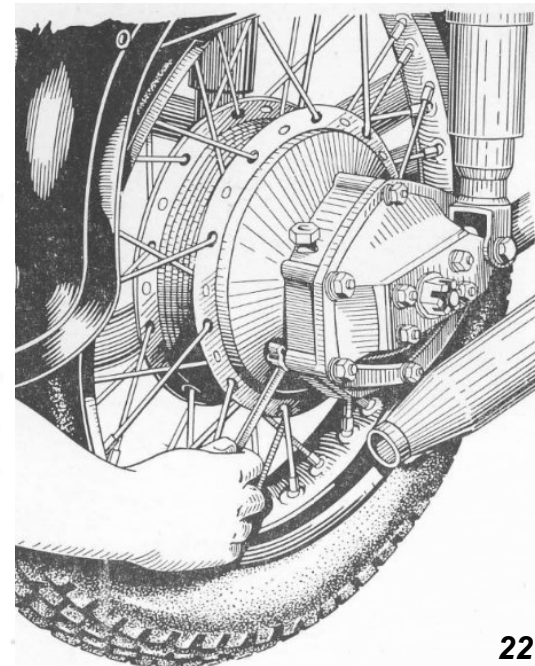
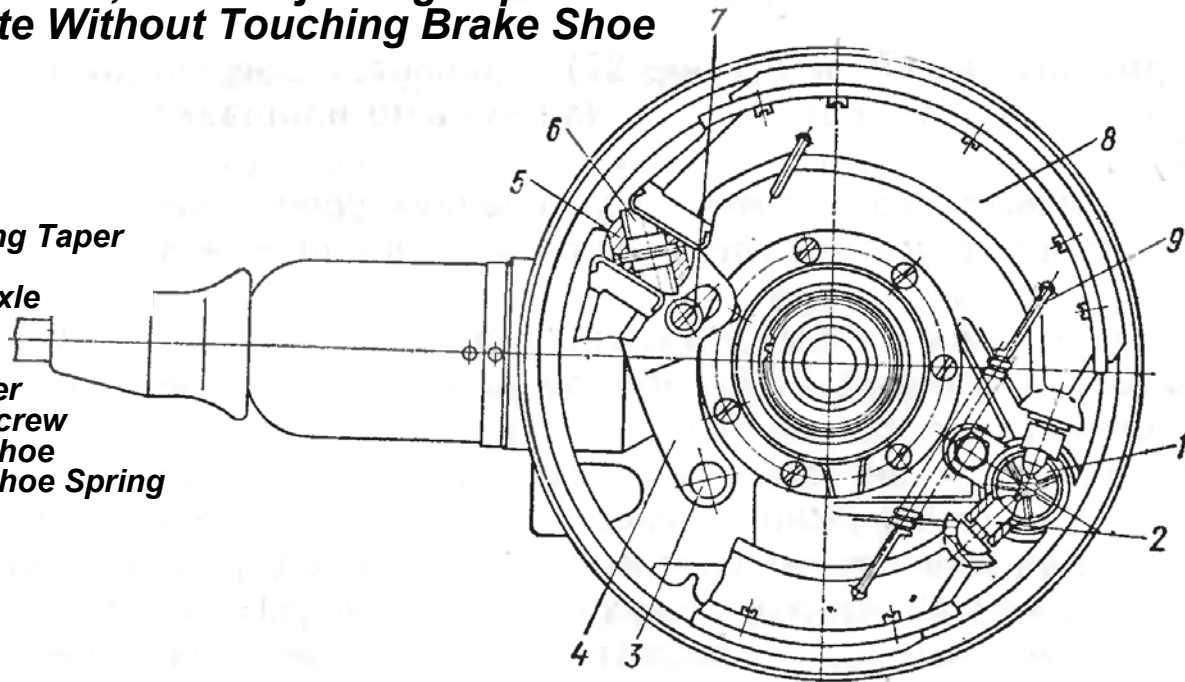

MB-650M1 Rear Wheel Brake Linkage

- Rear Wheel and Sidecar brake Actuated from Foot Pedal (2) via Equalizer (3)
- Upper Arm of Equalizer Connected to Control Linkage of Rear Wheel Brake
- Lower Arm Connected to Sidecar Wheel Brake
- Equalizer Ensures Correct Distribution of Braking Torques and Synchronous Operation between rear and Sidecar Brakes
- Length of Front Tie Rod (13) Ensures 3 to 9 mm (6 ± 3) from Equalizer Symmetry Plane to symmetry Plane of the Upper Arm of Brake Pedal (2)
- Brake Pedal Must Be Pressed to Footrest Rubber Roller at angle of 5° to 13°
- Length of Tie Rod (11) adjusted During Installation or Repair of Brakes
 - Adjustment Done with Wheel Removed, Brake assembled and Brake pedal Pressed to Footrest
 - Push Lever (10) forward and disengage Nut (8) from Lever
 - While Unscrewing Nut, Bring it to Axle (9) without a Clearance
 - Small Tension Is Admissible When Lower head of Lever (10) Is Shifted Forward thru a distance of Not Over 5 mm
 - Threaded Part of Tie Rod Must Not Be Buried in the Nut

1. Foot Rest Rubber Roller
2. Pedal
3. Equalizer
4. Stop-Light Switch
5. Cable Return Spring
6. Adjusting Union
7. Sidecar Wheel Brake Cable
8. Nut
9. Lever Axle
10. Brake Cam Lever
11. Rear Pull Rod
12. Intermediate Lever
13. Front Tie Rod
14. Adjusting Equalizer Bolt
15. Sleeve
16. Rear Tie Rod Fork
17. Outer Hinge Axle
18. Stop

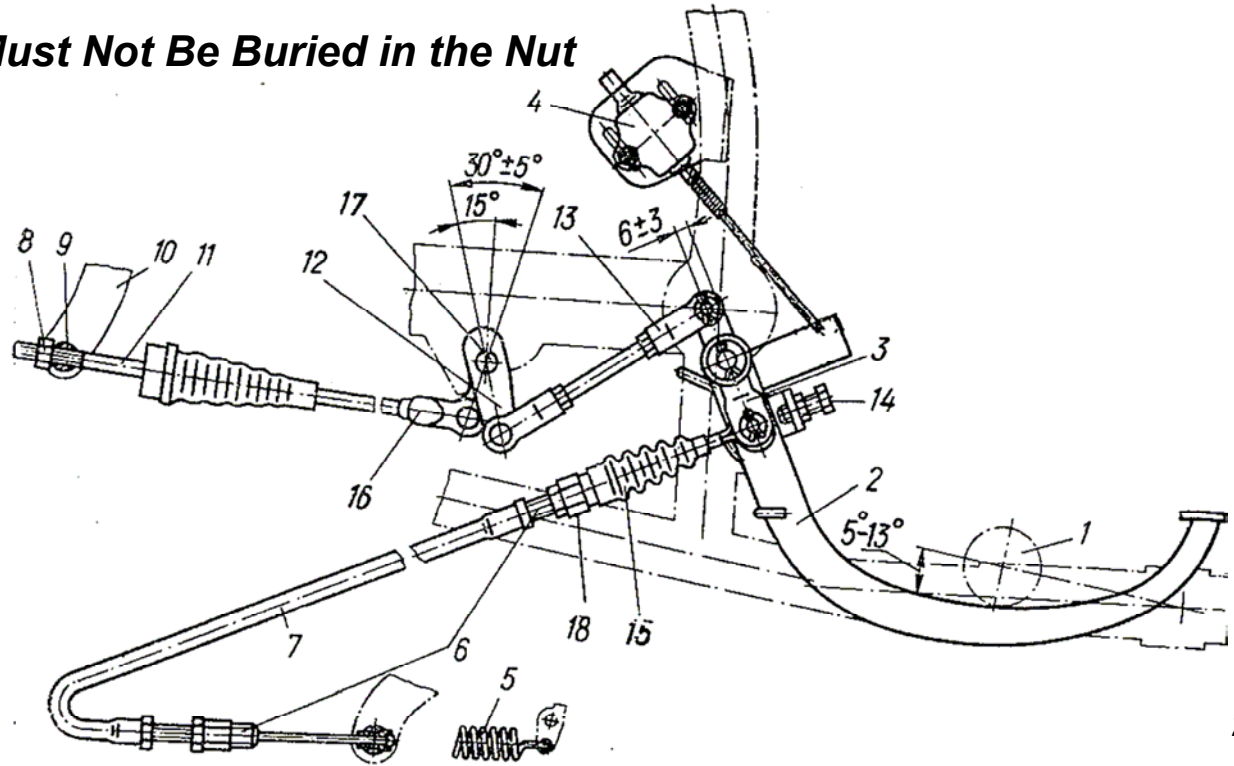

Dnepr MB-650M, MT-12 Rear Brake Drive Linkage

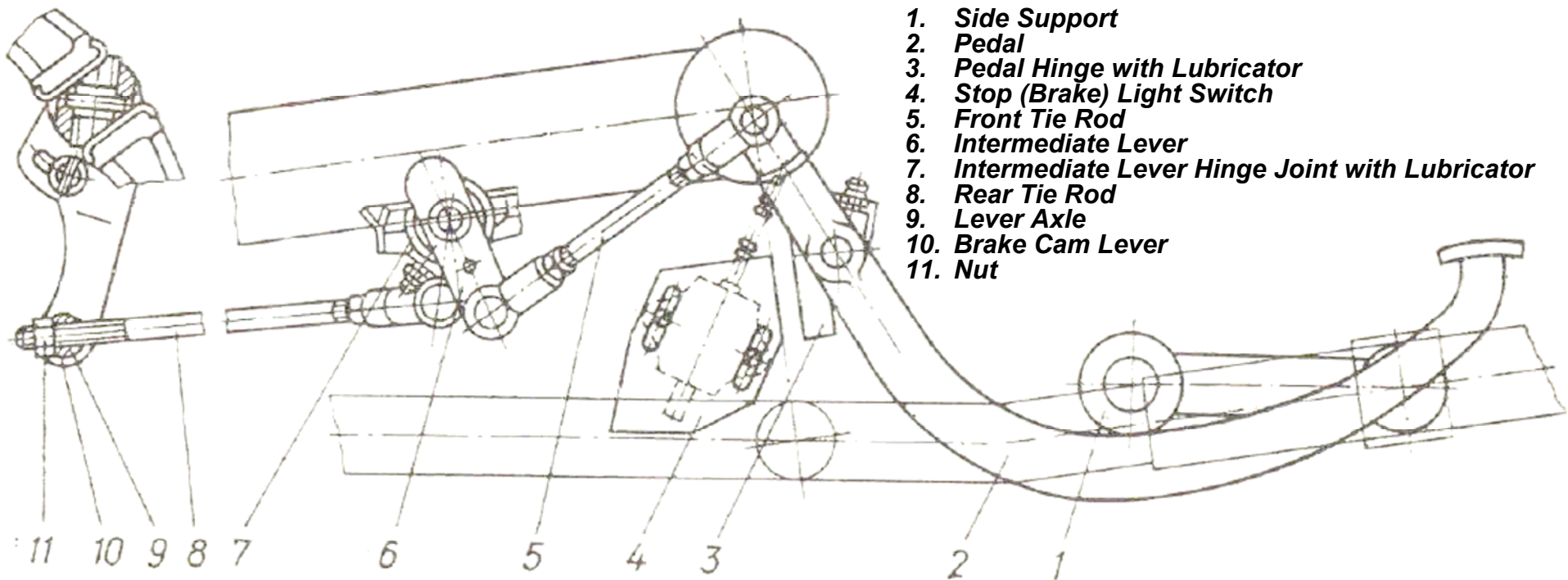

MB-650M1 Sidecar Wheel Brake

- **Similar Design to Rear Wheel Brake**
- **Actuated by Cable (7)**
- **Cable adjusting Unions (6) On Both Ends of Cable, with protective Rubber Sleeves (15)**
- **Check Brake Adjustment and Control Linkage When Sidecar Wheel Is Lifted**
- **First Check Clearance Adjustments Between Brake Shoes and Drum with Aid of Adjusting Taper, similar to Rear Wheel Adjustment**
 - **Position of Adjusting Unions (6) Must Exclude Action of Cable on the Lever of Brake Cam**
- **Next, Adjust tension of the Cable Using Unions (6)**
 - **First Set the Position of the Beginning of Braking the Wheel by Unscrewing the Unions**
 - **Then Release the Wheel Brake by Screwing In One of the Unions**
 - **With the Mounted Wheel, Tighten the Cable by the Union Until the Beginning of Braking**
 - **Slack Off Tension Until Wheel Freely Rotates**
 - **When Screwing or Unscrewing the adjustment Union from the Brake Side, There Is No Necessity of Removing the Protective Rubber Envelope**
 - **After Releasing the Attachment of the Cable from the Brake Pedal, the Union Can Be Rotated Together with the Cable**
- **Minimize Cable Friction on Rubber Envelopes during Adjustment by Slightly Shaking the Cable**
- **Excessive Tension of the Cable Can Interfere with the Equalizer Controlling Braking Distribution between the Rear Wheel and the Sidecar Wheel**
- **On Bracket of Pedal (2) Is Adjusting Equalizer Bolt (14), Which Limits the Turn of Equalizer (3)**
- **With the Correctly Adjusted Position of Bolt (14), the Clearance between Equalizer and the End of Bolt (14) Must Be between 2 to 3 mm When Pressing on the Pedal with a Force of 40 to 50kgf**
- **The Rest of the Equalizer in Bolt (14) Weakens the Action of the Sidecar Wheel**
- **Bolt (14) serves as a Stop for the Lower Arm of the Equalizer in the Event of a Cable Break**
- **Brake Parts Must Be Lubricated, Preventing Any Grease on Brake Linings**
- **Wear of Shoe Brake Linings Limited to Rivet Heads Recessed at least 0.3 mm**

Dnepr K-650, K-750B, K-750M, and MB-750 Front Wheel Brake Operation

- Parts of Front and Rear Wheel Brakes Are Interchangeable
- Design of Front Wheel
 - Brake Shoes (8) with Spherical Recesses Bear on Heads of Tappets (Pushers) (2) and with Pressure Surfaces on Cam (5)
 - Cam has a Slot with Equalizer (6) Fitted into It
 - When Cam Turns, Equalizer Turns Together with It Until Shoes Press to Brake Drum
 - Ensures Equal pressure on Both Shoes to Increase braking Efficiency
- Rear Brake of Similar Construction to Front Brake
- Brake Lining Wear
 - As Brake Linings Wear, Clearance Between Brake Shoes and Brake Drum Increases
 - Maintain Clearance Within Limits of 0.2 to 0.4 mm
 - When Required, Cone Is Screwed In, Pushing Aside Tappets (Pushers) (2), Which Move Brake Shoes Closer to Drum
 - Cone Is Screwed In from External Side of the Brake Disk
 - Lengthwise Grooves on Cone Surface Help Fix Cone in Position
 - Pushers Fit Them Under Pressure of Springs (9), Which Pull Brake Shoes Together
- Brake lever, Together with Cam, Located Either Inside the Brake Disk (for Front Wheel Brake) or from Inner Side of Final Drive Casting (for Rear Wheel Brake)
- Front Wheel Brake driven by Cable (2.16 mm dia.)
- Rear Wheel Brake Driven by Rigid Linkage System

1. Adjusting Cone
2. Pusher
3. Lever Axle
4. Lever
5. Cam
6. Equalizer
7. Lever Screw
8. Brake Shoe
9. Brake Shoe Spring

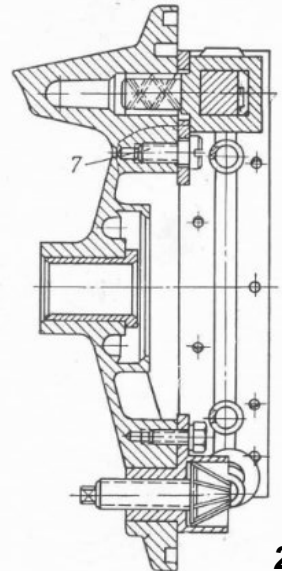
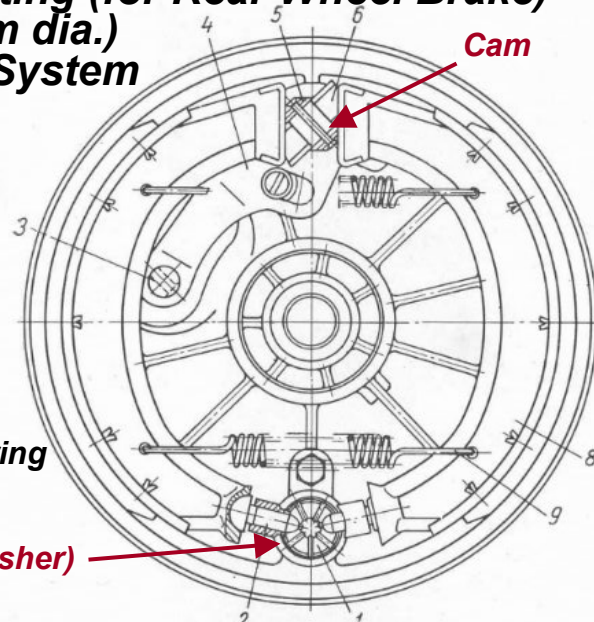

K-750B and MB-750

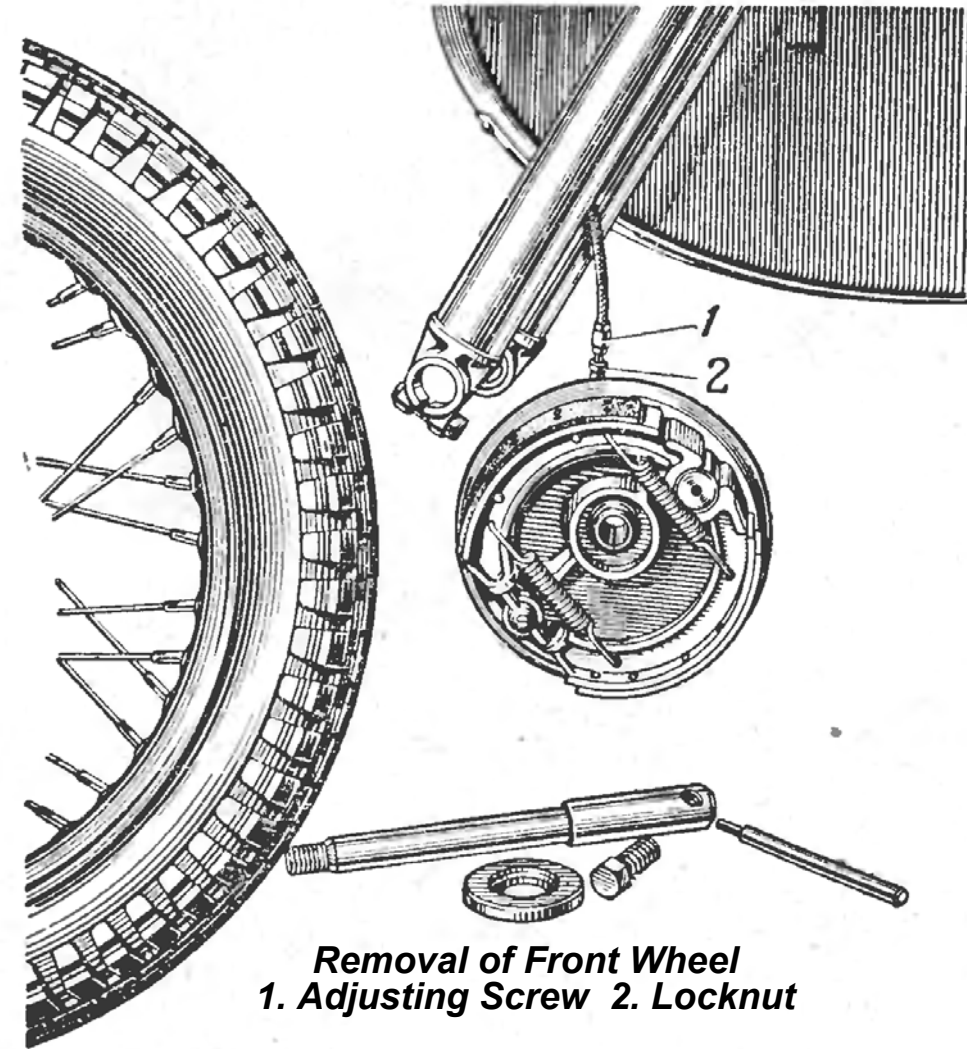

Removal of Front Wheel
1. Adjusting Screw 2. Locknut

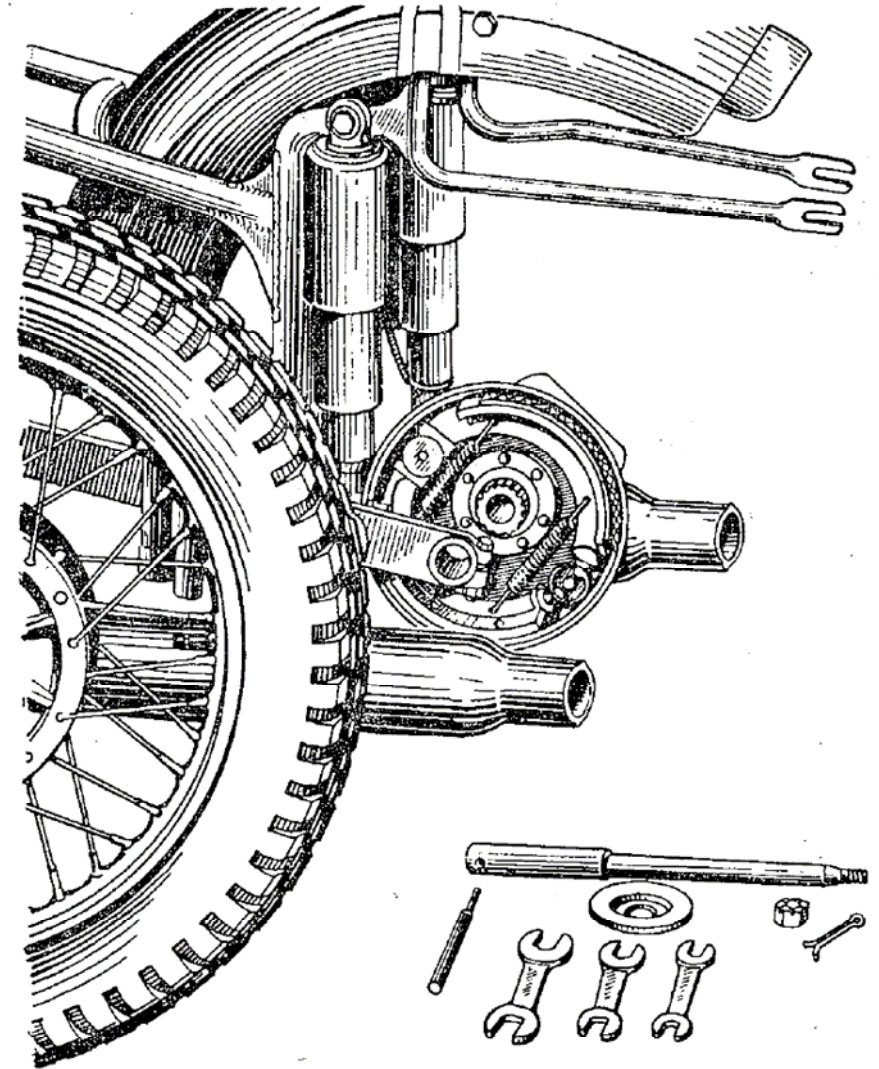

Removal of Rear Wheel